

58536A H01 GPS Distribution Amplifier Information Note

This information note describes accessory equipment for a Symmetricom GPS receiver system for a telecommunications network.

The accessory is a distribution amplifier for GPS antennas. Model 58536 H01 is designed to distribute the signal from a GPS antenna to as many as four GPS receivers.

For assistance, contact:

Symmetricom, Inc.
2300 Orchard Parkway
San Jose, CA 95131-1017

U.S.A. Call Center:
888-367-7966 (from inside U.S.A. only
– toll free)
408-428-7907

U.K. Call Center:
+44.7000.111666 (Technical
Assistance)
+44.7000.111888 (Sales)

Fax: 408-428-7998

E-mail: ctac@symmetricom.com

Internet: <http://www.symmetricom.com>

Warning Symbols Used In This Note



Instruction manual symbol; the product will be marked with this symbol when it is necessary for the user to refer to the instruction manual.



Indicates hazardous voltages.



Indicates earth (ground) terminal.



or



Indicates terminal is connected to chassis when such connection is not apparent.



Indicates Alternating current.



Indicates Direct current.

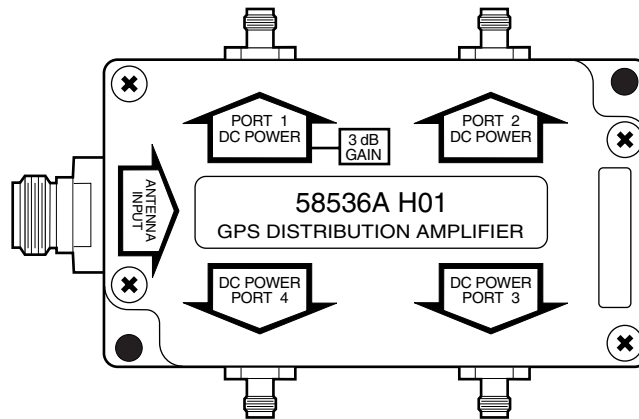

Figure 1. 58536A H01 GPS Distribution Amplifier

1.0 Introduction

The 58536A H01 GPS distribution amplifier is one component of a complete line of GPS accessories available from Symmetricom. These accessories are designed to deliver precise GPS signals over a wide temperature range and in harsh environmental conditions.

The distribution amplifier is required if you wish to distribute the signal from a single antenna to as many as four GPS receivers.

2.0 Description

The 58536A H01 consists of a broadband, unity gain amplifier and a 1:4 signal splitter. Designed for use with GPS antennas, the unit features a high degree of isolation to eliminate feedback and interaction between any GPS systems connected to it.

Power to the unit is supplied by a GPS timing receiver connected to one of the four ports. This means that the distribution amplifier will operate as long as there is at least one working GPS receiver connected to any one of the distribution amplifier ports.

3.0 Use with Non-Symmetricom Systems

Although designed for use with Hewlett Packard GPS receivers, the 58536A H01 can be used with other GPS receiver and antenna systems.

The 58536A H01 operates over a voltage range of +4.5 Vdc to +13 Vdc. Power from the GPS receiver is passed through to the antenna.

Note: When installing any electrical device always follow the rules prescribed by your local electrical and building ordinances. Contact Symmetricom as described below for additional technical recommendations for installation.

4.0 Considerations for Long Cable Runs

Due to process variations in the fabrication of the 58536A H01, the gain through the device can vary ± 3 dB. Assume the worst case loss of the 58536A H01 (-3 dB) when determining if line amplifiers are necessary in your GPS antenna system. If an amplifier is required, consider the 58529A line amplifier with L1 bandpass filter.

Note: In general, an amplifier is required if there is more than 20 dB of cable loss between the GPS antenna and the GPS receiver. Two amplifiers are recommended when there is more than 40 dB of cable loss.

Calculate cable loss:

The assumed worst case loss through the 58536A H01 (-3 dB) is equal to:

- 18 meters (60 ft) of cable length when using LMR 400 cable
- 8 meters (25 ft) of cable length when using RG-213 cable.

Use this procedure to determine if line amplifiers are required:

1. First, calculate the distance from the antenna to the most distant receiver.
2. Determine the signal loss due to the type and length of cable used.
3. Add the assumed worst case loss through the 58536A H01 in terms of cable length.
4. Compare the result to the requirements for line amplifiers below. If line amplifiers are required, they should be added as close to the GPS antenna as possible (within 10 meters/33 feet).

5.0 Requirements for Line Amplifiers

This section provides information that will help you determine if line amplifiers are required for your GPS antenna system installation.

For LMR 400 cable:

If the estimated cable length (include the cable length equivalent to the assumed worst case loss through the 58536A H01) between the antenna and the most distant GPS receiver is:

- Less than 115 meters (377 feet), no line amplifier is necessary.
- More than 115 meters (377 feet) and less than 240 meters (787 feet), you need 1 line amplifier.
- More than 240 meters (787 feet) and less than 360 meters (1181 feet), you need 2 line amplifiers.
- More than 360 meters (1181 feet), contact Symmetricom for assistance.

For RG-213 cable:

If the estimated cable length (include the cable length equivalent to the assumed worst case loss through the 58536A H01) between the antenna and the most distant GPS receiver is:

- Less than 53 meters (174 feet), no line amplifier is necessary.
- More than 53 meters (174 feet) and less than 105 meters (345 feet), you need 1 line amplifier.
- More than 105 meters (345 feet) and less than 158 meters (518 feet), you need 2 line amplifiers.
- More than 158 meters (518 feet), contact Symmetricom for assistance.

For Non-Symmetricom cable:

If using other cable, the need for amplifiers can be estimated using the following guidelines:

- If your installation involves less than 20 dB of cable loss, an amplifier is not required.
- If there is from 20 to 39 dB of cable loss, one amplifier will provide sufficient gain to ensure proper operation.
- If there is from 40 to 59 dB of cable loss, two amplifiers are recommended for proper operation. This is the maximum cable loss for which the GPS receiver can provide power. If you have calculated more than 60 dB of cable loss for your installation, then a lower-loss cable must be used. HP's lowest-loss standard cable is LMR 400 (58520A or 58521A) with a loss of 5 dB per 30.5 meters (100 ft). Contact Symmetricom if you need information on the availability of lower-loss cable.

Note: These guidelines include a safety margin to account for any degrading of signal strength due to temperature changes in the cable, variation of sensitivity in the antenna and receiver, and minor errors made in estimating cable loss.

6.0 Installation

The 58536A H01 distribution amplifier can be mounted in any indoor or outdoor location. It should be positioned after the antenna, any line amplifiers, and any lightning arrestors, as the last item before the GPS receivers.

Note: Protecting outdoor connections is recommended. Refer to Environmental Considerations for more information.

Environmental Considerations for Outdoor Installations

It is recommended that all cable connections that are outdoors or exposed to wet or humid environments be sealed to prevent moisture from entering the connector. For maximum protection, a multi-barrier process is suggested.

A Multi-Barrier Process

A multi-barrier process provides maximum protection for connections. An example of this process might consist of the following steps:

1. Wrap the connection with a self-fusing, insulating tape (for example, 3M Scotch™ 23 Rubber Splicing Tape).
2. Overwrap the self-fusing tape with a layer of vinyl electrical tape (for example, 3M Scotch™ Super 88 Vinyl Electrical Tape).

3. Cover with a layer of oil and water resistant coating (for example, 3M Scotchkote™ Electrical Coating).

Note: For specifics, please refer to the manufacturer's instructions.

Dimensions of Distribution Amplifier

Figure 2 shows the major dimensions of the distribution amplifier.

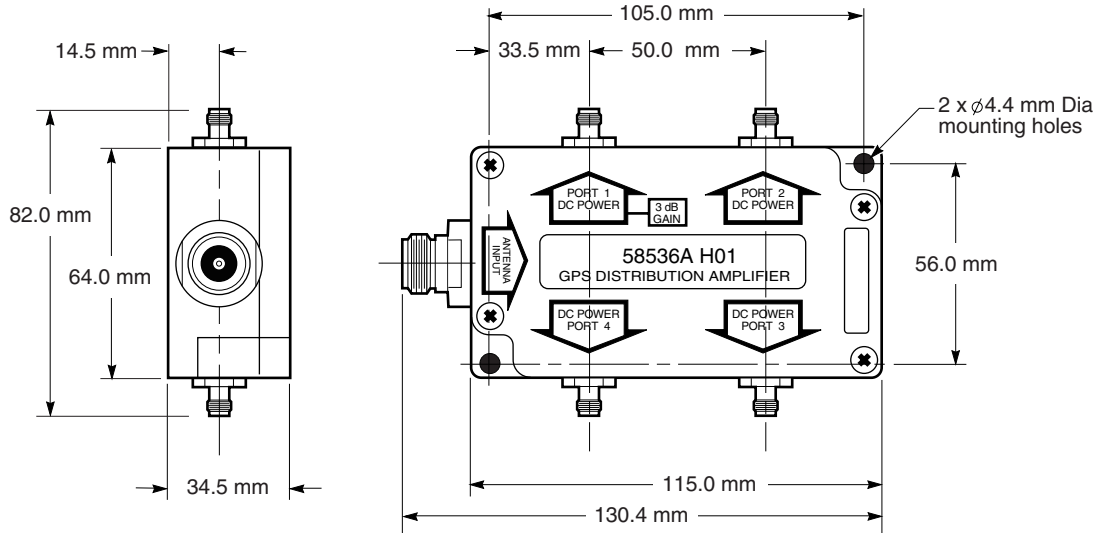

Figure 2. 58536A H01 GPS Distribution Amplifier

7.0 Maintenance

No periodic maintenance is required for the distribution amplifier. However, it is recommended that all components of the antenna system be checked periodically and replaced, if necessary, as specified in your company procedures.

8.0 Specifications/Characteristics

The following table presents the specifications for the 58536A H01 GPS Distribution Amplifier.

Table 1. 58536A H01 Specifications/Characteristics

Frequency Bandwidth (3 dB)	1575.42 MHz \pm 10 MHz (typical)
Gain (antenna to output)	Port 1: 3 dB \pm 3 dB (typical) @ 1575.42 MHz (L1) Ports 2-4: 0 dB \pm 3 dB (typical) @ L1
Noise Figure	5 dB (typical) @ 25°C
VSWR	Input: 1.2:1 (typical) @ L1 Output: 1.6:1 (typical) @ L1
Isolation	-23 dB (typical) @ 1575.42 MHz (L1) -50 dB (typical) @ $f \leq L1 - 40$ MHz -50 dB (typical) @ $f \geq L1 + 40$ MHz
DC Power Operating voltage* (see Caution below) Damage level Operating current	+4.5 Vdc to +13 Vdc > 18 Vdc, either polarity 23 mA to 48 mA (depending on operating voltage)
AC Input Level (antenna signal) Impedance Maximum operating Damage level	50 Ω , nominal -25 dBm +17 dBm @ L1
AC (output ports) Impedance	50 Ω , nominal
Connectors	Input: 1 Type-N Jack, Output: 4 Type-SMA Jacks
Operating Environment	-35°C to +75°C
Weight	0.5 kg
Dimensions (including connectors)	82 mm W x 130 mm L x 35 mm H
Mounting Holes	2 holes, 4.4 mm diameter

Caution: *Operating voltage is passed through to the antenna. The 58532A antenna operates on +5 Vdc nominal. Applying greater than +5 Vdc nominal may damage the 58532A.